

RotaBlast® RBP-2

Fully portable, open hopper, (Wet/Dry) abrasive blasting system

THE WORLD'S MOST EFFICIENT ABRASIVE BLASTING SYSTEM



Main Features

- Blasting pressure: 05-125PSI
- Non-pressurized Hopper
- Single blast hose - no additional remote lines
- Adjustable blasting pressure
- "On-demand" abrasive metering
- Blast wet or dry
- Safe & easy-to-use controls
- Safety Proof Design
- Maintenance free hopper
- Fill with abrasive whilst in use
- Dual Induction Blast Nozzle

Benefits of RotaBlast Technology

- No pressure vessel regulations
- **40% Less Air Consumption**
- No moisture mixed with stored abrasive from compressed air – no blockages
- Ultra-efficient flow controlled abrasive pickup
- **Blast 24/7 - without any downtime**
- High-performance blasting
- Super-precise abrasive & water dose adjustment
- Safe & easy-to-use
- Lightweight & portable – typically half the weight of a similar sized "welded pressure pot"

www.rotablast.com
sales@rotablast.com



Global Patent(s) Pending:
US 2022-0297264 A1,
GB2603137.7, GB2600608.0

RotaBlast® RBP-2 Tech Specs

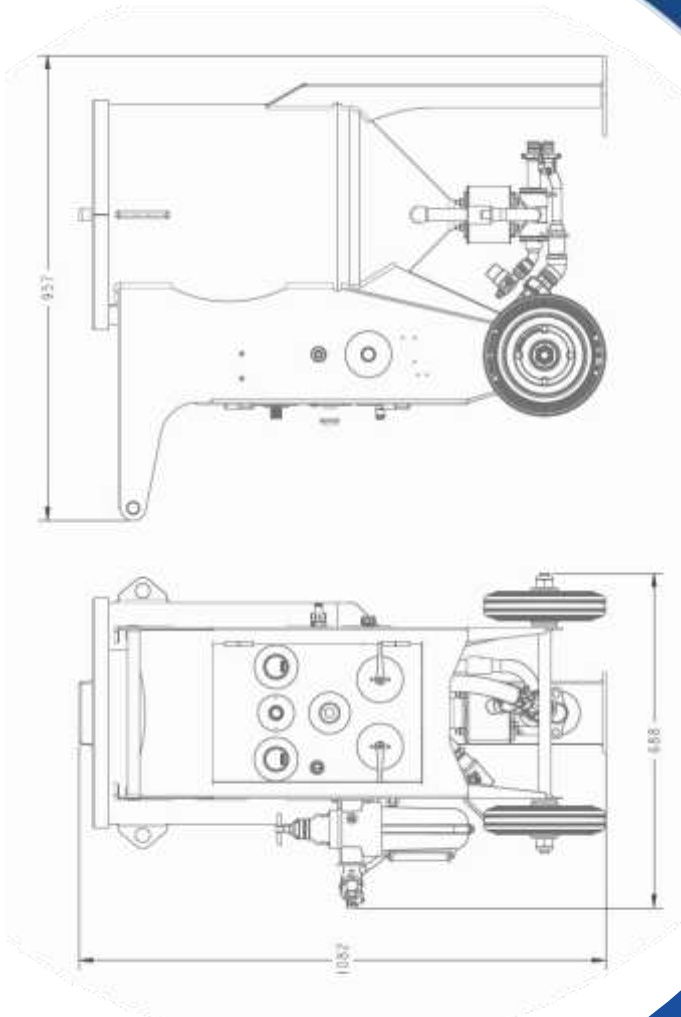

Standard Specifications

- High-flow filter regulator
- Water/air filtration system
- Normally closed abrasive metering valve
- 10M blast hose
- Pot-lid with built-in sieve
- Long life silicone-nitride blast nozzle liner

Optional Extras

- Blast hose extensions up to 300ft
- Breathing filter regulator
- Air-fed helmet
- Abrasive control @ Nozzle
- Fully ATEX rated systems

Machine Specifications

- Dry Weight: 115kg
- Hopper Capacity: 80-Litres
- Abrasive Consumption: 45-80kg p/hr
- Water Consumption: ~1-1.5-litre per minute
- Maintenance free hopper
- No pressure vessel regulations
- No abrasive moisture accumulation
- Air flow required: 70-300cfm (depending on nozzle size)
- Blast Pressure: Adjustable 05-125PSI
- All RotaBlast® systems come with a 2-year parts & labor warranty

AUTHORIZED DEALER STAMP



Global Patent(s) Pending:

US 2022-0297264 A1,

GB2603137.7, GB2600608.0